

HYDROPHONES
BC 31x, ZET 32x
USER MANUAL

CONTENT

Introduction.....	3
1 Description and Operation	4
1.1 Purpose	4
1.2 Structure.....	4
1.3 Package	5
1.4 Structure and Operation	6
1.5 Example of configuration when connecting the BC 311 Hydrophone to the spectrum analyzer via the ZET 440 Amplifier	9
2 Intended Use	11
2.1 Preparation for use and operation	11
2.2 Explosion protection in installation and operation	11
3 Maintenance.....	13

Introduction

This User Manual (hereinafter – Manual) is used for the operation and maintenance of BC 31x type hydrophones (BC 311, BC 312, BC 313 models) and ZET 32x hydrophones (ZET ZET 321 and 323 models) (hereinafter – the Hydrophones) by the maintenance personnel.

The Manual describes the operation, design of the Hydrophone models, as well as connection dimensions and modes of connecting the Hydrophones to the measuring equipment.

The Hydrophones must be operated only by the personnel who studied this Manual and trained on safety instructions.

The Manufacturer reserves the right to make minor changes to the design and scheme of the Hydrophones not affecting the specifications.

At all stages of operation of the Hydrophones, follow this Manual and other documents supplied with the Hydrophones.

This Manual and Data Sheet are included with the Hydrophones and must be kept with them.

One Manual is provided per batch of 10 Hydrophones.

1 Description and Operation

1.1 Purpose

1.1.1 The Hydrophones are designed to measure sound pressure in liquid media.

1.1.2 The Hydrophones comply with TU 4212-001-76603936-2012.

1.2 Structure

The BC 311, BC 312, BC 313, ZET 321 and ZET 323 Hydrophones are available in submersible and mortise versions.

The Hydrophones are non-recoverable, non-repairable, and non-dismountable devices.

Structurally, the Hydrophone consists of a sealed housing, which comprises a piezoelectric sensor element (piezoelectric element) and a low-noise cable with a connector.

The housing of the Hydrophones is made of stainless steel. The Hydrophone housing has no electrical contact with the sensor element, the internal circuit of the Hydrophone and the power cable.

To provide mechanical, hydrolytic and chemical protection, the piezoelectric element is protected by a compound sound-transparent coating.

The appearance of Hydrophones is shown on Fig. 1.1.



Fig. 1.1 The Hydrophone appearance

1.3 Package

The basic package is shown in Table 1.1.

Table 1.1 Basic package

Name	Quantity	Note
Hydrophone	1 pc.	The model is determined when ordering.
Connecting cable	1 pc.	The length is determined when ordering.
Data Sheet	1 copy	
User Manual	1 copy	1 document per batch of NMT 10 pcs.

1.4 Structure and Operation

1.4.1 The Hydrophone operation is based on the direct piezoelectric effect of piezoceramic materials: when the sound pressure is applied to the surface of the piezoceramic element, an electric charge is generated on its electrodes proportional to the effective pressure.

1.4.2 The Hydrophone models differ from each other in metrological specifications listed in their Data Sheets.

1.4.3 The BC 313 and ZET 323 Hydrophones have built-in amplifiers with differential output.

1.4.4 The BC 311 and ZET 321 Hydrophones are not equipped with built-in amplifiers and reversible, so they can be used both as receivers and signal emitters.

1.4.5 The BC 312 Hydrophone is equipped with a pre-amplifier to transfer signals over a ICP standard two-wire cable.

1.4.6 The block diagrams of the Hydrophones (BC 311, ZET 321), BC 312, (BC 313, ZET 323) are shown on Fig. 1.2-Fig. 1.4.

1.4.7 The BC 311 and ZET 321 Hydrophones are connected to the measuring equipment (spectrum analyzer, etc.) via a charge amplifier (ZET 440 model).

1.4.8 The BC 312 Hydrophone equipped with an ICP circuit is connected directly to the measuring equipment with ICP input (for example, to the spectrum analyzers of the ZET 03x models).

1.4.9 The BC 313 and ZET 323 Hydrophones are connected to the measuring equipment via the ZET 430 adapter.

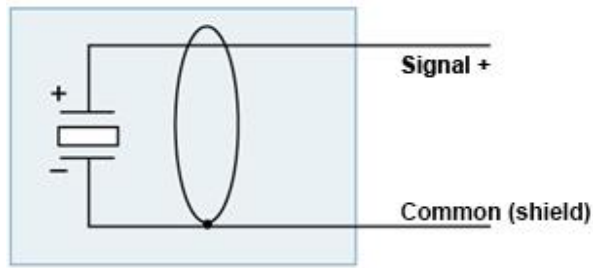

Fig. 1.2 Block diagram of the BC 311 and ZET 321 Hydrophones

Table 1.2 Designation of the BC 311 and ZET 321 outputs

Signal output	Name
Signal +	Signal output
Common (shield)	Common power wire – cable shield

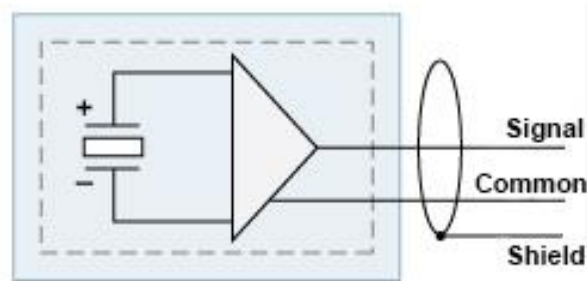

Fig. 1.3 Block diagram of the BC 312 Hydrophones

Table 1.3 Designation of the BC 312 outputs

Signal output	Name
Signal	ICP output
Common	Common power supply wire
Shield	Cable shield

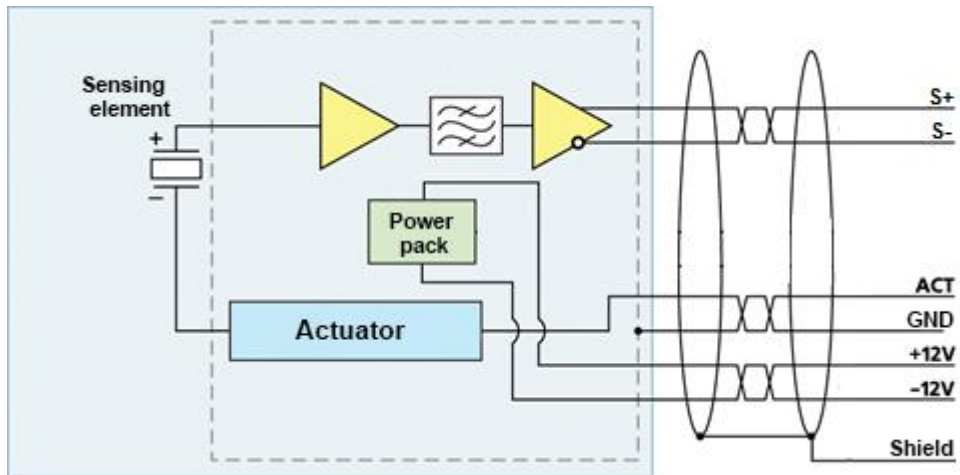

Fig. 1.4 Block diagram of the BC 313 and ZET 323 Hydrophones

Table 1.4 Designation of the BC 313 and ZET 323 outputs

Cable output No.	Designation	Name
1	-12V	Power supply -12 V
2	+12V	Power supply +12V
3	S-	Differential output -
4	S+	Differential output +
5	Common (GND)	Common power supply wire
6	ACT	Electrical control (calibration) input
7	Cable shield	Cable shield

1.5 Example of configuration when connecting the BC 311 Hydrophone to the spectrum analyzer via the ZET 440 Amplifier

1. Prepare the Amplifier according to item 3.3.
2. Connect the BC 311 Hydrophone to the Charge input of the ZET 440 Amplifier.
3. In the front view of the ZET 440 Charge Amplifier, set the gain according to Fig. 1.5.



Fig. 1.5 Settings tab

4. Go to the settings of the analyzer channel to which the ZET 440 Charge Amplifier is connected, as shown in Fig. 1.6.

The image is a screenshot of the ZET Device Manager software interface. It shows a table with columns for device name, sensitivity, frequency, ICP, constant gain of external amplifier, reference value, offset DC, input type, charge amplifier, gain, range, and X, Y, Z, Axis. The BC311 device is highlighted in blue.

Device	Sensitivity	Frequency	ICP	Constant gain of exter. amplifier	Reference value	Offset DC	Input type	Charge amplifier	Gain	Range	X	Y	Z	Axis
ZET 022 N#78321														
Bruel	0.0441 V/Pa	50 kHz	Yes	1	2e-05	0	AC	No	1	230	0	0	0	o
BC311	0.001 V/mV	50 kHz	No	1	0.001	0	AC	No	1	10000	0	0	0	o
	0.001 Pa	50 kHz	No	1	0	-3	DC	No	1	3	0	0	0	No

Fig. 1.6 ZET Device Manager tab

5. In the Measuring channel tab, set the properties of the analyzer channel according to Fig. 1.7.

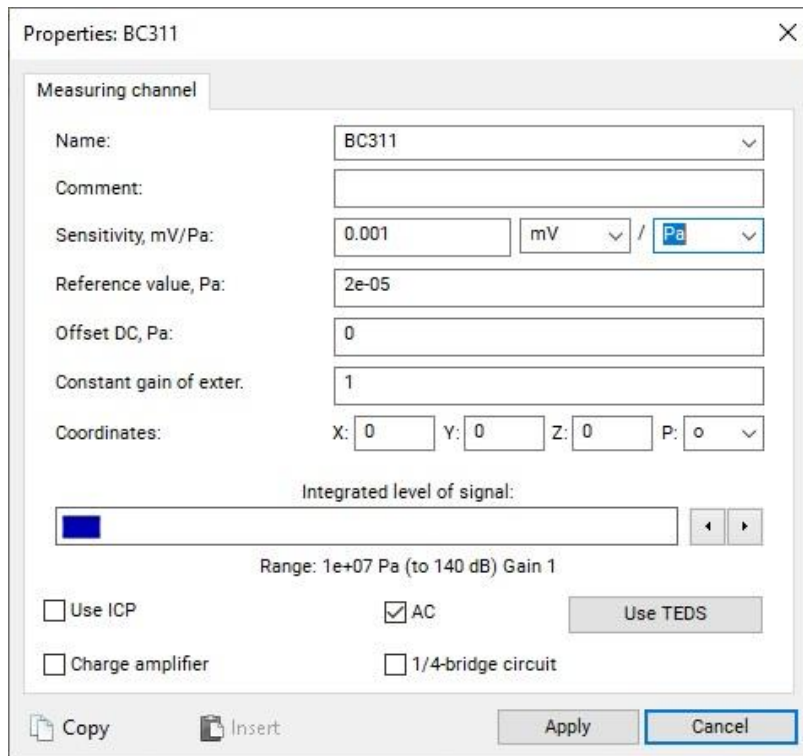

Fig. 1.7 Measuring Channel tab

In the Sensitivity, V/unit field, enter the sensitivity of the BC 311 Hydrophone as specified in the Data Sheet.

***ATTENTION!!!** The ZET 440 Amplifier's charge gain is 1 mV/pC. Therefore, sensitivity in pC/Pa is equal to sensitivity in mV/Pa when connected via a ZET 440 Amplifier. Accordingly, when connecting the Hydrophone to the spectrum analyzer via the ZET 440 Amplifier, if the Hydrophone sensitivity according to the Data Sheet is 0.44 pC/Pa, enter 0.00044 V/Pa in Sensitivity, V/unit field (see Fig. 1.7).*

2 Intended Use

2.1 Preparation for use and operation

2.1.1 The BC 311, ZET 321, BC 312, BC 313 and ZET 323 Mortise Hydrophones are mounted on the pipeline flanges or tank flanges using a threaded joint on the Hydrophone housing. When installing the Hydrophone at the site of operation, disconnect the Hydrophone cable from the receiver or adapter, and do not twist the cable. During the installation, do not damage the Hydrophone housing and the cable output. When installing and operating the Hydrophone, do not bend the connecting cable. When installing, take into account that vibration can be transmitted to the Hydrophone via a stretched cable.

2.1.2 The BC 311, ZET 321, BC 312, BC 313 and ZET 323 Submersible Hydrophones are positioned in the operating position under their own weight on the cable, or fixed at the tank bottom or other vessel with a liquid medium. When installing and operating the Hydrophone, do not bend the connecting cable. During the operation of Hydrophones, prevent sensitive elements from touching any other item or surface.

2.2 Explosion protection in installation and operation

2.2.1 The Hydrophones must be installed and operated only by the persons who studied this Manual and the appropriate instructions.

2.2.2 Before the installation, the Hydrophones must be inspected. During the inspection, pay attention to the following:

- explosion protection marking, "X" sign and warning signs;
- no damage to the shells;
- availability of all fasteners and locking devices;
- availability and condition of sealing equipment;
- availability of grounding devices.

2.2.3 The Hydrophones with a threaded connection type must be screwed in to the full length of the thread.

2.2.4 When operating the Hydrophones, pay special attention to the explosion protection devices, inspect them regularly, pay attention to:

- integrity of the shells (no dents, cracks, etc.);
- availability of the explosion protection marking, "X" sign and warning signs;
- condition of the grounding devices.

2.2.5 During the routine inspections, perform all monthly inspection works, check the following:

- reliable sealing of the cable input. Before testing, power off the Hydrophone. When checking, fix the cable firmly in the seal assembly;

– quality of the explosion-proof surfaces of the shell parts to be disassembled.

2.2.6 Mechanical damage to explosion-proof surfaces is not allowed. Do not operate the Hydrophones with damaged explosion protection parts.

3 Maintenance

The Hydrophones must be maintained only by the personnel having at least III Safety Qualification Group in accordance with the Safety Rules for Operation of Customers' Electrical Installations, practical skills and experience in the explosion-proof equipment operation and installation.

Before maintaining the Hydrophones installed in an explosive zone, power them off.

Do not perform the remedial works and repair of the Hydrophones in the explosive zones.